

INFO

Stud Welding

What is stud welding and how does it work?

The 12 most important questions and answers ...



Time and cost savings
New design potentials
Unsurpassed economy



Advantages

Questions + Answers

Stud welding processes

Pad welding process

Stud Welding

Advantages ...

*In many areas stud welding is the **most economic** fastening method for components. If using thin plates, stud welding is often the **only** technical solution.*

*With this **HBS** information brochure we want to show you the advantages of our technology.*

After answering the 12 most important questions about stud welding, we provide you with an overview on different stud welding processes as well as the innovative MARC-technology (pad welding with rotating ARC).

HBS – A step ahead!



Advantages

Questions + Answers

Stud welding processes

Pad welding process

Tremendous time and cost savings

No: drilling – punching – threading – gluing
riveting – screwing – finishing

New design potentials

- ➔ *Very low distortion by extremely short welding time.*
- ➔ *No leaking caused by drilled holes.*
- ➔ *High strength.*
- ➔ *One-sided accessibility of the component is sufficient.*
- ➔ *Weldable even onto very thin plates.*
- ➔ *Joining of different materials is possible.*

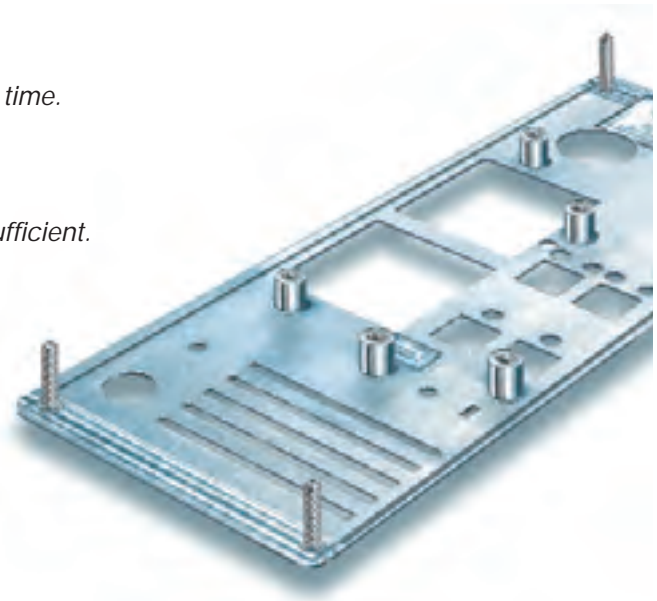

Unsurpassed economy

- ➔ *Can be automated to a very high degree.*
- ➔ *Very short welding time (1 msec to 1.5 sec), fast weld rates.*
- ➔ *Fast and easy handling leads to high productivity.*
- ➔ *No marks on backside of coated or high alloyed plates.*
- ➔ *Low prices for standard studs.*



The 12 most important questions and answers ...

1. What is stud welding?

- ➔ *Welding elements like threaded studs, pins, tapped pads etc. are welded by an arc without additional material.*



2. How does stud welding work?

- ➔ *An arc is ignited between the face of the stud and the surface of work piece; once both parts are melted, the stud is smoothly pressed against the work piece and then joined together.*



3. What kind of processes are available?

- ➔ **Capacitor discharge stud welding with tip ignition (TS)** according to DIN ¹⁾. Especially suited for welding on thin plates from about 0.5 mm. Minimum plate thickness: 1/10 of stud diameter. Welding range: M3-M8 (M10).
- ➔ **Drawn arc stud welding (DS)** according to DIN ¹⁾, process variations: drawn arc stud welding with ceramic ferrule or shielding gas; short cycle drawn arc stud welding; capacitor discharge drawn arc stud welding. Especially suited for welding on thicker plates of 2 mm and above. Minimum plate thickness: 1/8 of stud diameter. Welding range: dia. 2 to 25 mm (M24).

See page 10-15; pad welding see page 16-17



4. Where is stud welding used?

- ➔ **Capacitor discharge stud welding:** sheet metalwork, electronic industries, switchboard cabinets, laboratory and medical equipment, food industry, household appliances, communications engineering, vending machines, windows, glass constructions, insulation technology, industrial kitchens etc.
- ➔ **Drawn arc stud welding:** steel construction, mechanical engineering, shipbuilding, structural and civil engineering, power plants and combustion systems, boiler and plant equipment, insulation and window construction.

1) DIN EN ISO 14555

5. How strong is the joint?

- ➔ *Because the stud is joined with the work piece over the whole surface of the stud, the strength of the joint is even higher than the base material or the stud.*

6. Which materials are weldable?

Generally materials of the same kind should be welded.*

- ➔ **Capacitor discharge stud welding** according to DIN ¹⁾²⁾ :
steel (mild and alloyed steel), aluminum, brass.
- ➔ **Drawn arc stud welding** according to DIN ¹⁾²⁾ :
steel (mild and alloyed steel), aluminum.

** Other materials/combinations on request.*

¹⁾DIN EN ISO 14555 ²⁾DIN EN ISO 13918



7. Which stud diameter and stud length can be welded?

- ➔ **Capacitor discharge stud welding** according to DIN ²⁾:
M3 to M8 (M10), dia. 2 to 10 mm
- ➔ **Drawn arc stud welding** according to DIN ²⁾:
dia. 2 to 25 mm (M24)

Lengths: Ask for the HBS-brochure "Product survey – Stud Welding Fasteners".

8. Which stud shapes are available?

- ➔ **Capacitor discharge stud welding** according to DIN ²⁾: threaded studs, pins, tapped pads, christmas tree studs, paint clearing studs, grounding clips, cupped head pins, insulation pins.

- ➔ **Drawn arc stud welding** according to DIN ²⁾: threaded studs, pins, tapped pads, christmas tree studs, concrete anchors, collar studs, insulation pins.

HBS supplies any type of standard welding elements as well as special studs to customer's request.

Ask for the HBS-brochure "Product survey – Stud Welding Fasteners".

²⁾ DIN EN ISO 13918



9. How long does the welding process last?

- ➔ *Capacitor discharge stud welding: 1 to 3 msec*
- ➔ *Drawn arc stud welding: 5 msec to 1.5 sec*

10. Which quality of the plate surface is required?

- ➔ *The surface of the plate must be electrically conductive.*
- ➔ *Varnish, aluminum layers, scale, rust and plastic surfaces are to be removed. Check galvanized and oily plates for their weldability.*



11. How many studs per minute can be welded?

- ➔ *Manual stud feeding: 5 to 6 studs per minute* (average).*
- ➔ *Automatic stud feeding: 40 studs per minute* (average).*

** Production rate depends on application and type of HBS studwelders.*



Advantages

Questions + Answers

Stud welding processes

Pad welding process

12. How to automate stud welding?

➔ **HBS** delivers a wide product range: Starting with a hand held welding gun with automatic stud feeding, semi-automatic systems, up to fully automated stud welding units and robotic applications. Single source – by **HBS**.

Ask for our HBS-brochure "Product survey – Automatic Stud Welding".

Very suitable to weld various welding elements onto work pieces of different component heights.

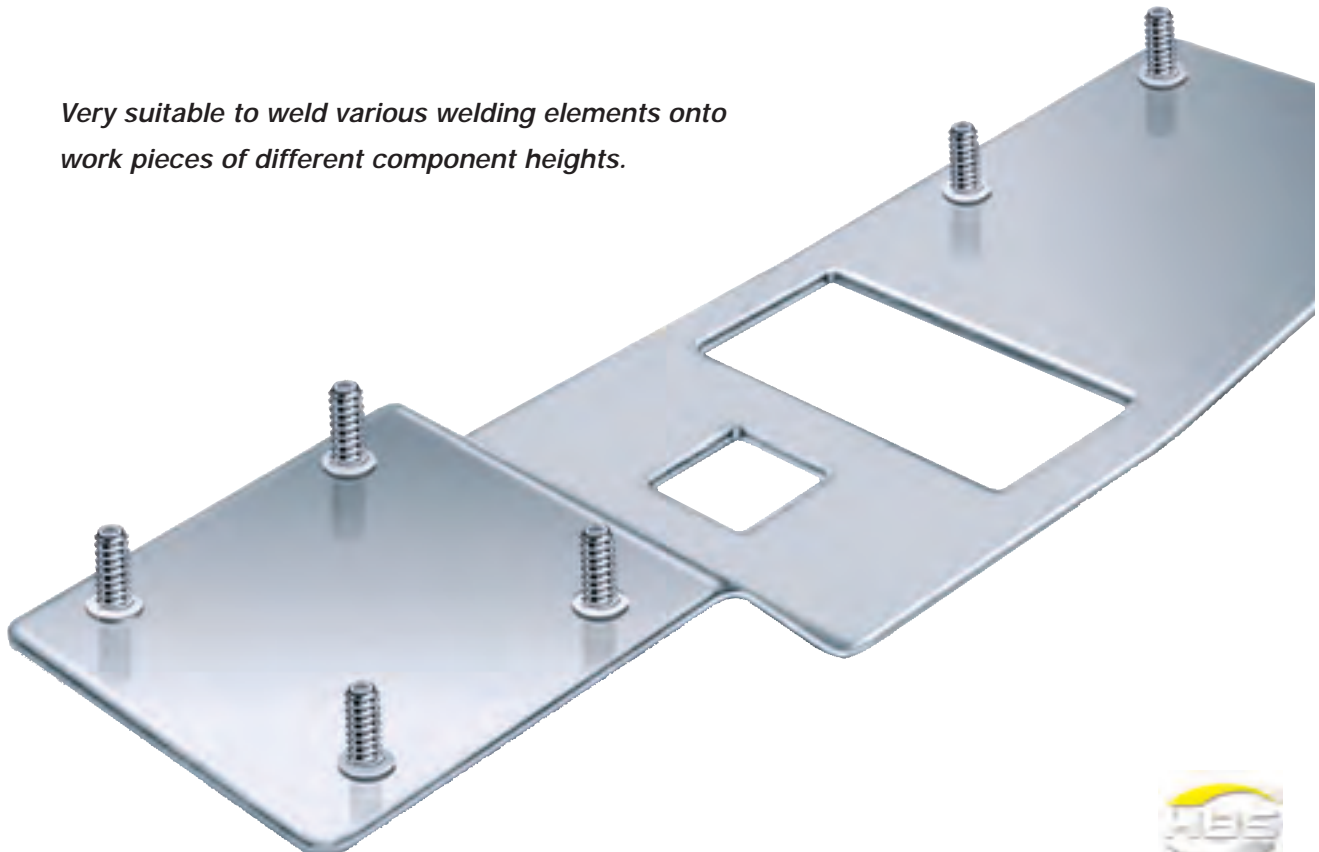

The stud welding processes ...

CD Capacitor discharge stud welding with tip ignition

with contact

- ➔ *The capacitor battery will be charged according to chosen charging voltage.*
- ➔ *The stud (with ignition tip) is placed onto the work piece and pressed by a spring in the welding gun onto the work piece (contact). The current circuit is closed.*
 - ➔ *After triggering the welding process, the rapidly increasing current evaporates the ignition tip and ignites the arc.*
 - ➔ *Stud and work piece are melted.*
 - ➔ *The stud is moved forward to the plate.*
 - ➔ *The arc is cut as soon as the stud touches the work piece.*
 - ➔ *The molten zones are joining and solidifying.*
 - ➔ *Welding time is ≤ 3 msec.*
 - ➔ *Recommended plate thickness should be $1/10 d$, but not less than 0.5 mm.*

Ask for our **HBS**-brochure "CD – Stud Welding Systems for CD-Welding".

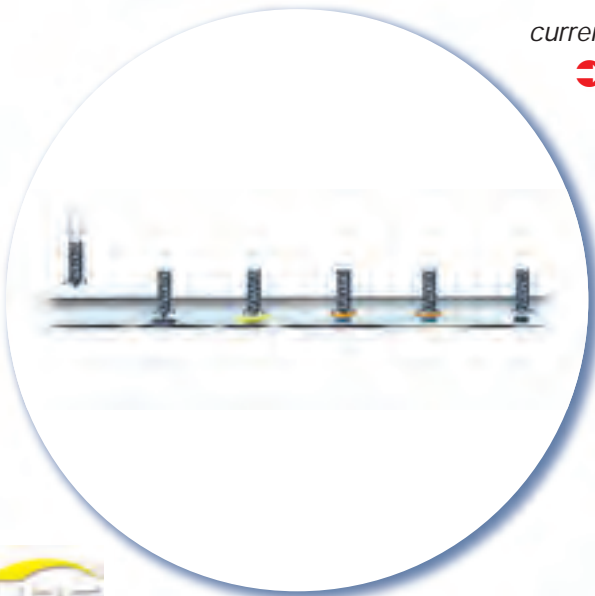

Advantages

Questions + Answers

Stud welding processes

Pad welding process

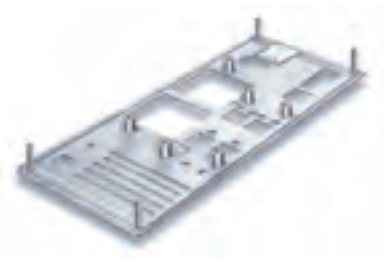

with gap

➔ *Gap welding is different from the procedure described above: Before welding starts, the stud is positioned in a defined and adjustable distance above the work piece (gap).*

➔ *After triggering the welding process, the stud is accelerated by a spring to the plate surface.*

➔ *If there is contact between the ignition tip on the work piece, the process continues as described above.*

➔ *Welding time is approx. 1 msec; thus e.g. welding of aluminum becomes feasible without using a shielding gas atmosphere.*

➔ *Recommended plate thickness should be $1/10 d$, but not less than 0.5 mm.*

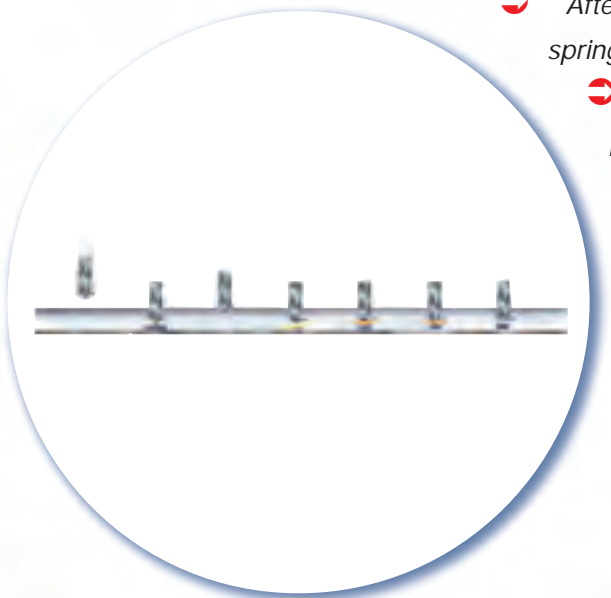

Advantages

Questions + Answers

Stud welding processes

Pad welding process

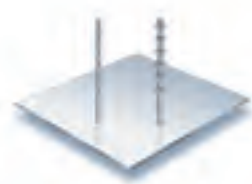
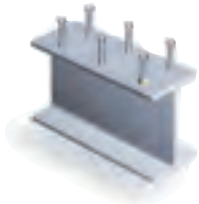

ARC Drawn arc stud welding with ceramic ferrule or shielding gas

- ➔ The stud is inserted into the chuck and – if necessary – equipped with a ceramic ferrule.
 - ➔ The stud is placed onto the work piece.
 - ➔ A lift mechanism in the welding gun or welding head lifts the stud.
- A secondary arc (pilot arc) of low current is ignited between stud tip and work piece.

➔ Then the ignition of the main arc is carried out between stud tip and work piece.

➔ Stud and work piece are melted.

➔ At the end of the adjusted welding time the stud is moved to the work piece, the two molten zones join. The power source is switched off, the weld pool solidifies and cools down.

➔ The ceramic ferrule is removed after welding.

Ask for our **HBS**-brochure
"ARC/SC – Stud Welding Systems for ARC-Welding".



Advantages

Questions + Answers

Stud welding processes

Pad welding process

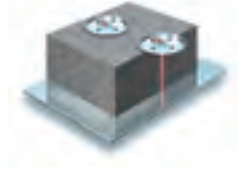

ISO Welding

processes for insulation

Cupped head welding pin ISO Plus (HVAC)

The welding process of cupped head pin welding corresponds with the technique for capacitor discharge stud welding with tip ignition with contact (CD).

- ➔ *The insulating mat is fastened in one single working operation.*
- ➔ *Very favorable fastening system.*
- ➔ *No damage to the backside (even with galvanized plate) > 1 mm.*

*Ask for our **HBS**-brochure "ISO – Fastening Systems for Insulation"*

*Specially developed **HBS** system to weld cupped head pins (for fastening of heating, ventilation, air-conditioning and fire insulation mats).*



Advantages

Questions + Answers

Stud welding processes

Pad welding process

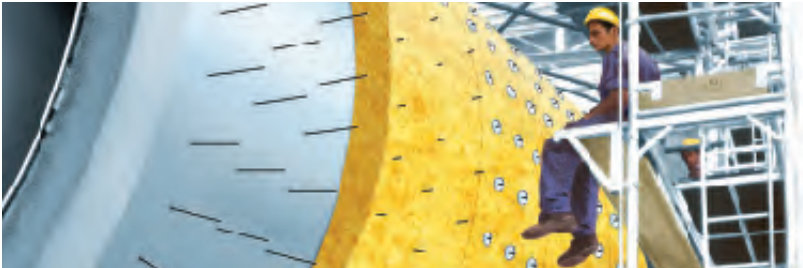

Fire-resistant insulation with ARC-insulation pins (FRI)

The welding process of ARC-insulation pin welding corresponds with short cycle drawn arc stud welding (SC).

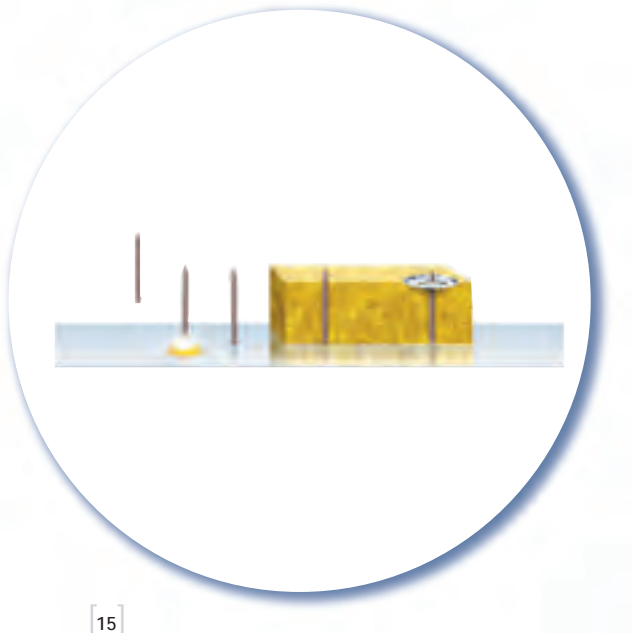

Welding elements for fire-resistant insulation on request.



The pad welding process

MARC Pad welding with magnetic rotating ARC



A weld pool is generated under the entire area of the stud on stud welding process like drawn-arc and tip ignition.

MARC welding is a variation of drawn arc stud welding. A magnetic field is rotating the arc and a weld pool on the entire surface of the cylindrical pad is generated.

Using this procedure, you can weld on through-hole and dead end-hole applications, as well as on curved work piece surfaces.

Ask for our HBS-brochure "MARC – Pad and Nut Welding".



Advantages

Questions + Answers

Stud welding processes

Pad welding process



Functional welding sequence:

- ➔ *The pad is placed onto the base material – the current circuit is closed.*
- ➔ *Preflow of shielding gas.*
- ➔ *Power unit is switched on and arc voltage is provided. Coil current is switched on and magnetic field is generated.*
 - ➔ *Lift of pad.*
 - ➔ *Ignition of pilot arc and then ignition of welding arc between pad and plate.*
 - ➔ *Burning of rotating arc along the ring-shaped welding area.*
 - ➔ *At the end of welding time, the pad is lowered and plunged into the liquid weld pool.*
 - ➔ *Electrical short-circuit and cut-off of welding current.*
 - ➔ *Formation and solidification of weld seam with post-flow time of shielding gas.*



● head office ▲ subsidiary ■ joint venture



HBS

A step ahead!

Our ability to develop new products using state of the art technology is shown by multiple worldwide patents and numerous national and international industry awards.



HBS

A step ahead!



Distributed in Australia by

všP]vŀPwŀjS

tW vŀŀXμ
Wŀŀ ŀ
u]oW všPvŀŀXμ

EŀW ŀ
s/W ŀ
YŀW ŀ
tW ŀ
W ŀ

