

## B84P Brass Ball Valve For Gas & Potable Water

B84L Ball valve avoids water stagnation and the spread of bacteria in the system.

### Key Features include:

- 24h 100% seal test guaranteed
- Dual sealing system allows valve to be operated in either direction making installation easier
- No metal-to-metal moving parts
- No maintenance ever required
- Handle clearly shows ball position
- Silicone-free lubricant on all seals
- Travel stops on body to avoid stresses at stem
- Chrome plated brass ball for longer life with rinse hole

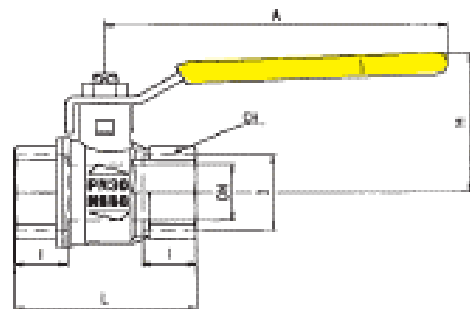

Pressure - Temperature Chart

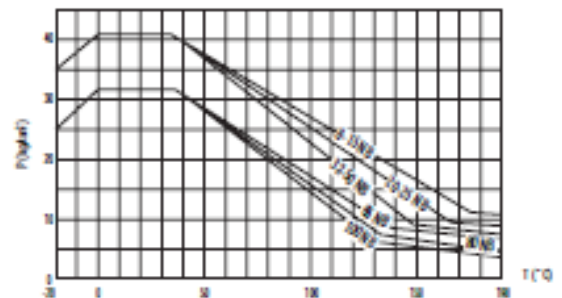

Product Details	
Thread	BSPP
Flow	Full
Connections	F/F
Application	Gas Water Drinking Water
Stem Configuration	Two O-Ring
Handle	Lever
Body	Brass
Seats	G/F PTFE
Sizes	10 – 65mm

