













## Slimline Universal LED Exit Light

TRADELIKE



### FEATURES

- Low 3w standby power consumption
- Includes both single and double sided decals in running man and the arrow decal
- Large terminal block & cable entry
- Polycarbonate body with transparent acrylic blade
- Wall, ceiling single-sided & ceiling double-sided mount
- Maintained
- Manual test switch
- 2200mAh lithium battery technology
- Designed and manufactured to AS/NZS2293.3

### DIMENSIONS

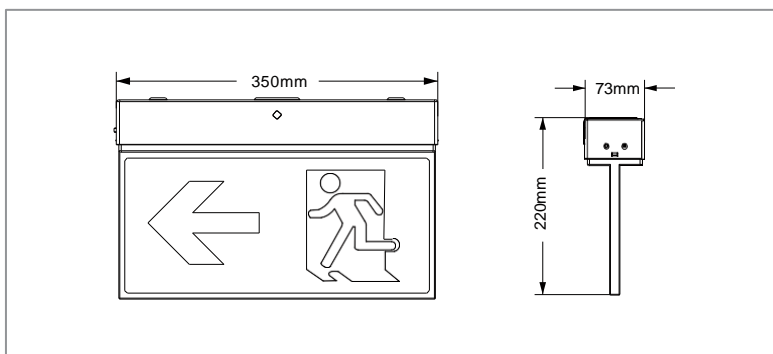

### SPECIFICATIONS

Antec Order Code	EL-UNI-SLIM
Input Voltage	240v
Construction	Polycarbonate body with transparent acrylic blade
Mounting	Ceiling and wall
Operating Mode	Maintained
Testing System	Manual
Battery	Lithium 2200mAh 3 hour discharge
Classification	C0: D12.5 C90: D8
Viewing Distance	24m
Applicable Standard	AS/NZS2293.3
Lamps	LED 50,000hrs
Operating Temp	-20 to 40°C
Dimensions (mm)	350x220x73
Weight	1.42kg

## Slimline Universal LED Exit Light Black

TRADELIKE



### FEATURES

- Low 3w standby power consumption
- Includes both single and double sided decals in running man "Pictograph" and the "EXIT" decal
- Large terminal block & cable entry
- Polycarbonate body with transparent acrylic blade
- Wall, ceiling single-sided & ceiling double-sided mount

#### Maintained

- Manual test switch
- 2200mAh lithium battery technology
- Designed and manufactured to AS/NZS2293.3

### DIMENSIONS

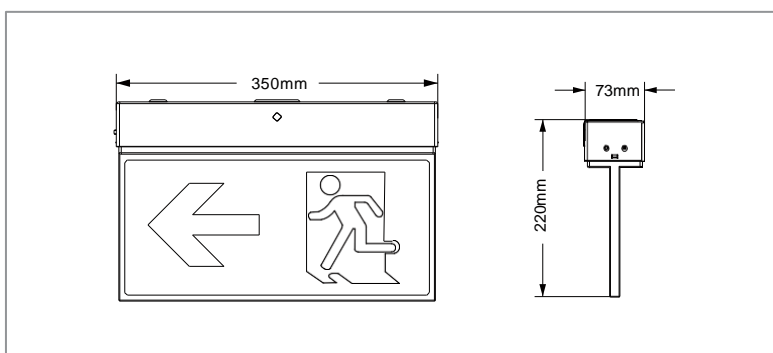

### SPECIFICATIONS

Antec Order Code	EL-UNI-SLIM-BLK
Input Voltage	240v
Construction	Polycarbonate body with transparent acrylic blade
Mounting	Ceiling and wall
Operating Mode	Maintained
Testing System	Manual
Battery	Lithium 2200mAh hour discharge
Classification	C0: D12.5 C90: D8
Viewing Distance	24m
Applicable Standard	AS/NZS2293.3
Lamps	LED 50,000hrs
Operating Temp	1°C to 40°C
Dimensions (mm)	350x220x73
Weight	1.42kg



## Recessed Blade LED Exit Light

TRADELIKE



Emergency



SAA



### FEATURES

- Low 3w standby power consumption
- Includes both single and double sided decals in running man "Pictograph" and the "EXIT" decal
- Large terminal block & cable entry
- Polycarbonate body with transparent acrylic blade Maintained
- Manual test switch
- Cutout size - 430x75mm
- 2200mAh lithium battery technology
- Designed and manufactured to AS/NZS2293.3

### DIMENSIONS

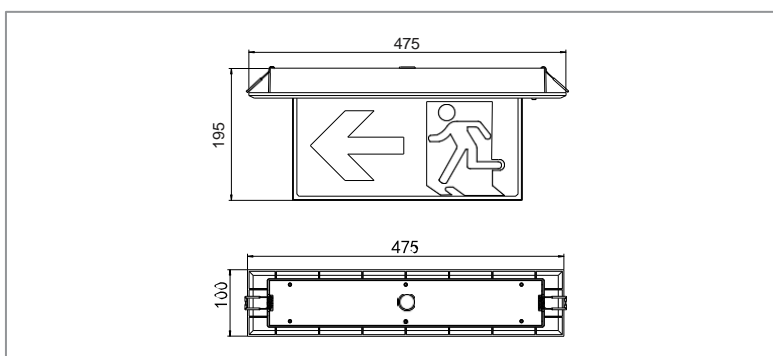

### SPECIFICATIONS

Antec Order Code	EL-BLADE-REC
Input Voltage	240v
Construction	Polycarbonate body with transparent acrylic blade
Mounting	Ceiling
Operating Mode	Maintained
Testing System	Manual
Battery	Lithium 2200mAh 3 hour discharge
Classification	C0: D12.5 C90: D8
Viewing Distance	24m
Applicable Standard	AS/NZS2293.3
Lamps	LED 50,000hrs
Operating Temp	1C° to 40C°
Dimensions (mm)	475x195x100
Weight	1.56kg

## Recessed Blade LED Exit Light Black

TRADELIKE



### FEATURES

- Low 3w standby power consumption
- Includes both single and double sided decals in running man "Pictograph" and the "EXIT" decal
- Large terminal block & cable entry
- Polycarbonate body with transparent acrylic blade Maintained
- Manual test switch
- Cutout size - 430x75mm
- 2200mAh lithium battery technology
- Designed and manufactured to AS/NZS2293.3

### DIMENSIONS

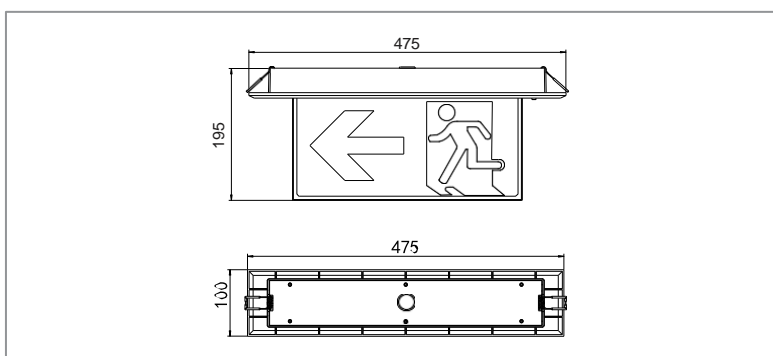

### SPECIFICATIONS

Antec Order Code	EL-BLADE-REC-BLK
Input Voltage	240v
Construction	Polycarbonate body with transparent acrylic blade
Mounting	Ceiling
Operating Mode	Maintained
Testing System	Manual
Battery	Lithium 2200mAh 3 hour discharge
Classification	C0: D12.5 C90: D8
Viewing Distance	24m
Applicable Standard	AS/NZS2293.3
Lamps	LED 50,000hrs
Operating Temp	1°C to 40°C
Dimensions (mm)	475x195x100
Weight	1.56kg

## Weatherproof LED Exit Light

TRADELIKE



### FEATURES

- Low power consumption
- 50,000hr LED - energy efficient
- Wall and ceiling mount
- Easy testing and maintenance
- Maintained
- 3 hour runtime in emergency mode
- 3 year warranty
- 2200mAh lithium battery technology
- Designed and manufactured to AS/NZS2293.3

### DIMENSIONS

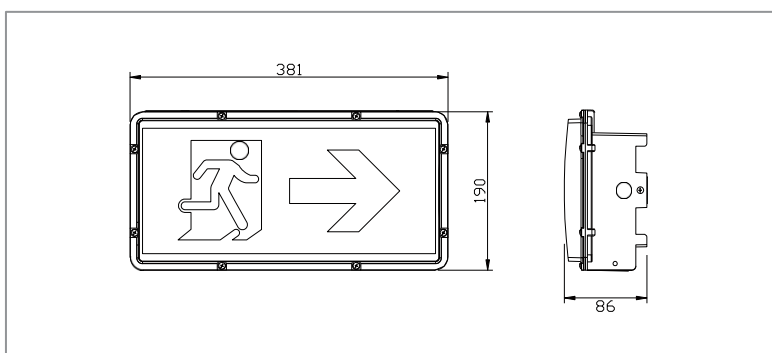

### SPECIFICATIONS

Antec Order Code	EL-WALL-WPROOF
Input Voltage	240v
Construction	Polycarbonate with stainless steel clips
Mounting	Ceiling and wall
Operating Mode	Maintained
Testing System	Manual
Battery	Lithium 2200mAh 3 hour discharge
Classification	C0: D12.5 C90: D8
Viewing Distance	24m
Applicable Standard	AS/NZS2293.3
Lamps	LED 50,000hrs
Operating Temp	1°C to 40°C
Dimensions (mm)	381x190x86
Weight	1.56kg

## Ceiling Mount LED Exit Light

TRADELIKE



### FEATURES

- Low power consumption
  - 50,000hr LED - energy efficient
  - Wall and ceiling mount
  - Easy testing and maintenance
- Maintained
- 3 hour runtime in emergency mode
  - 3 years warranty
  - 2200mAh lithium battery technology
  - Designed and manufactured to AS/NZS2293.3

### DIMENSIONS

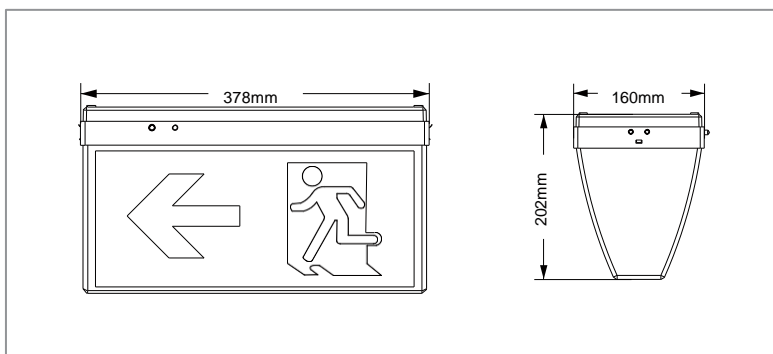

### SPECIFICATIONS

Antec Order Code	EL-WIDE-CEILING
Input Voltage	240v
Construction	Polycarbonate
Mounting	Ceiling and wall
Operating Mode	Maintained
Testing System	Manual
Battery	Lithium 2200mAh 3 hour discharge
Classification	C0: D12.5 C90: D8
Viewing Distance	24m
Applicable Standard	AS/NZS2293.3
Lamps	LED 50,000hrs
Operating Temp	1°C to 40°C
Dimensions (mm)	378x202x160
Weight	1.56kg

## Wall Mount LED Exit Light

TRADELIKE



Emergency



SAA



### FEATURES

- Low power consumption
- 50,000hr LED - energy efficient
- Wall and ceiling mount
- Easy testing and maintenance

#### Maintained

- 3 hour runtime in emergency mode
- 3 year warranty
- 2200mAh lithium battery technology
- Designed and manufactured to AS/NZS2293.3

### DIMENSIONS

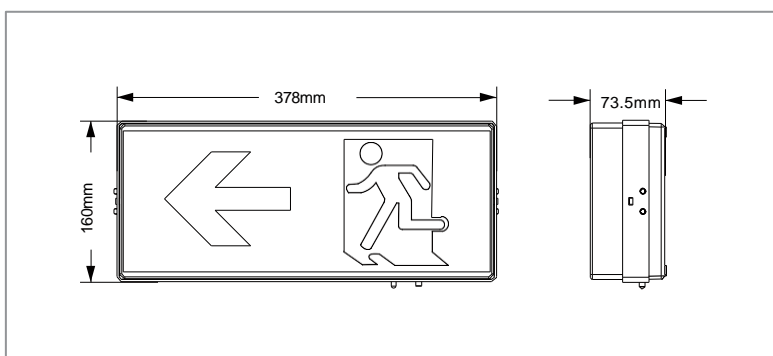

### SPECIFICATIONS

Order Code	EL-WALL-STD
Input Voltage	240v
Construction	Polycarbonate
Mounting	Ceiling and wall
Operating Mode	Maintained
Testing System	Manual
Battery	Lithium2200mAh 3 hour discharge
Classification	C0: D12.5 C90: D8
Viewing Distance	24m
Applicable Standard	AS/NZS2293.3
Lamps	LED 50,000hrs
Operating Temp	1C° to 40C°
Dimensions (mm)	378x160x73.5
Weight	1.56kg

## 2ft Widebody T8 LED Emergency Batten

TRADELIKE



### FEATURES

- Batters feature quality components and superior finish to provide both good looks and reliability
- Developed for applications such as basement car parks, ware- houses, fire stairs, commercial public spaces and industrial sites
- Low power consumption
- Wall & ceiling mount
- Easy testing and maintenance
- 2200mAh lithium battery technology
- Designed and manufactured to AS/NZS2293.3

### DIMENSIONS

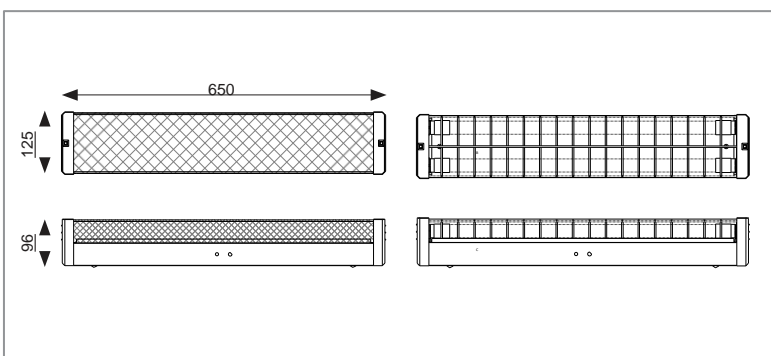

### SPECIFICATIONS

Antec Order Code	EL-BATT-2FT-DIFF
- Diffused	EL-BATT-2FT-WIRE
- Wire Guard	
Input Voltage	240v
Wattage	2 x 10w 2 x 3w (Emergency)
Lumen Output	2000lm
Operating Mode	Sustained
Beam Angle	100°
Classification	CO=D50C90=D20
Applicable Standard	AS/NZS2293.3
Construction	Powder coated steel body with polycarbonate lamp holders
Lamps	2 x T8 LED tubes 6000k 10w
Terminal Block	12mm
Dimming Options	No
Dimensions (mm)	650x125x96
Weight	2.3kg

## 4ft Widebody T8 LED Emergency Batten

TRADELIKE



### FEATURES

- Battens feature quality components and superior finish to provide both good looks and reliability
- Developed for applications such as basement car parks, ware- houses, fire stairs, commercial public spaces and industrial sites
- Low power consumption
- Wall & ceiling mount
- Easy testing and maintenance
- 2200mAh lithium battery technology
- Designed and manufactured to AS/NZS2293.3

### SPECIFICATIONS

Antec Order Code	EL-BATT-4FT-DIFF
- Diffused	EL-BATT-4FT-WIRE
- Wire Guard	
Input Voltage	240v
Wattage	2 x 18w 2 x 3w (Emergency)
Lumen Output	4000lm
Operating Mode	Sustained
Beam Angle	100°
Classification	CO=D50C90=D20
Applicable Standard	AS/NZS2293.3
Construction	Powder coated steel body with polycarbonate lamp holders
Lamps	2 x T8 LED tubes 6000k 10w
Terminal Block	12mm
Dimming Options	No
Dimensions (mm)	1255x125x96
Weight	2.3kg

### DIMENSIONS

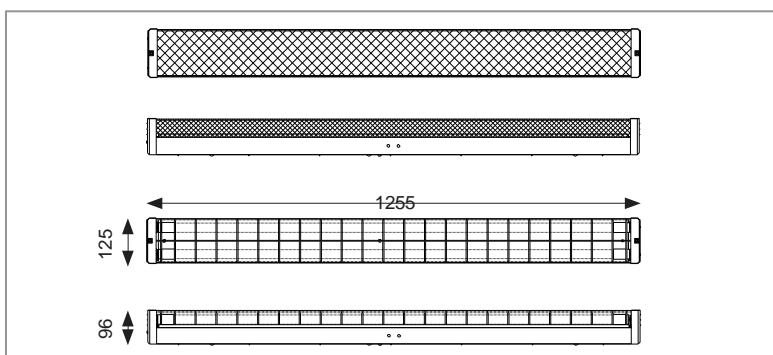

## Weatherproof Batten LED T8 tube Emergency

TRADELIKE



### FEATURES

- Fitted with large terminal block allowing for fast installation and maintenance
- Wide body to cover junction boxes and provides ample space for heat generating components
- Constant current driver
- 3 hour discharge
- Polycarbonate base and tamper proof stainless steel clips
- 2 x 10w / 2 x 18w
- LED 30,000hr life
- Designed and manufactured to AS/NZS2293.3

### DIMENSIONS

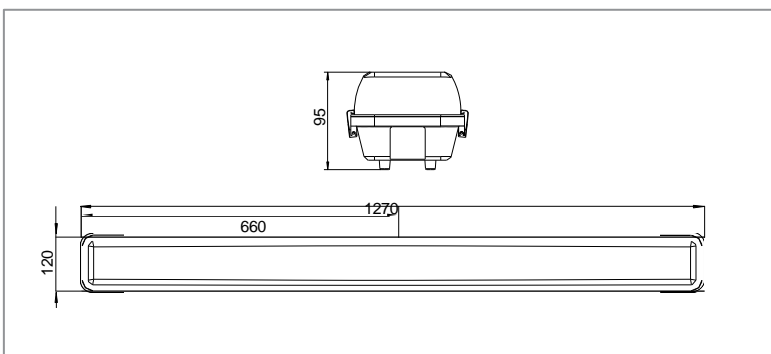

### SPECIFICATIONS

	2ft	4ft
Antec Order Code	EL-BATT-2FT-WPROOF	EL-BATT-4FT-WPROOF
Input Voltage	240v	
Wattage	2 x 10w 6w (Emergency)	2 x 18w 6w (Emergency)
Lumen Output	2000lm	3600lm
Operating Mode	Sustained	
Classification	C0=D63 C90=D20	
Applicable Standard	AS/NZS2293.3	
Beam Angle	100°	
Construction	Powder coated steel body with polycarbonate lamp holders	
Lamps	2 x T8 LED tubes 6000k 18w	
Terminal Block	12mm	
Dimming Options	No	
Dimensions (mm)	660x120x95	1270x120x65
Weight	2.5kg	5kg



## LED Opal Batten Tri-Colour w/ Microwave Sensor Socket

TRADELIKE

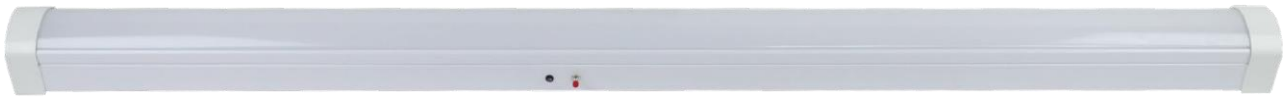

### FEATURES

- 20w/40w power selectable (4 foot only)
- Batten features a safety chain allowing installer to mount the base while batten hangs free saving time traveling up and down ladder during installation
- Fitted with large terminal block allowing for fast installation and maintenance
- Wide body to cover junction boxes and provides ample space for heat generating components
- Optional microwave sensor (MS01)
- Designed and manufactured to AS/NZS2293.3

### DIMENSIONS

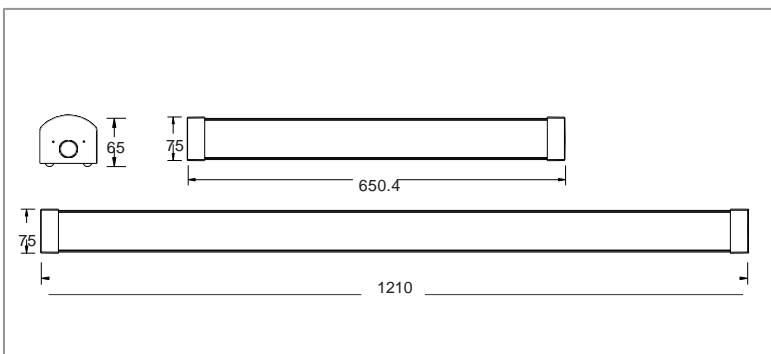

### SPECIFICATIONS

	2ft	4ft
Antec Order Code	EL-BATT-2FT-TRI	EL-BATT-4FT-TRI
Input Voltage	240v	
Wattage	20w 6w (Emergency)	20w/40w 6w (Emergency)
Lumen Output	2000lm	2000/4000lm
Operating Mode	Maintained	
Classification	C0=D63 C90=D20	
Applicable Standard	AS/NZS2293.3	
Battery	1800mAh	
Beam Angle	100°	
Colour Temp	Tri-colour 3000k, 4000k, 5700k	
Terminal Block	10mm	
Sensor Options	Yes	
Dimensions (mm)	650.4x75x65	1210x75x65
Weight	2kg	4kg

## Widebody LED Weatherproof Batten

TRADELIKE



### FEATURES

- 20w/40w power selectable (4 foot only)
- Fitted with large terminal block allowing for fast installation and maintenance
- Wide body to cover junction boxes and provides ample space for heat generating components
- Tri-colour 3000k/4000k/5700k - switchable
- 30,000hr life
- LED CCT panel
- Optional microwave sensor (MS01)
- Designed and manufactured to AS/NZS2293.3

### DIMENSIONS

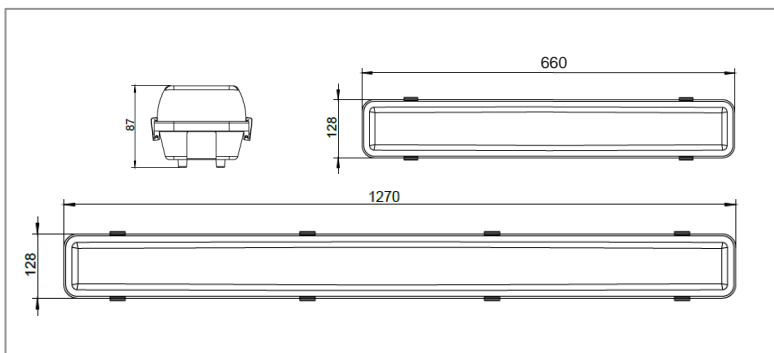

### SPECIFICATIONS

	2ft	4ft
Antec Order Code	EL-BATT-2FT-WPROOF	EL-BATT-4FT-WPROOF
Input Voltage	240v	
Wattage	20w 6w (Emergency)	20w/40w switchable 6w (Emergency)
Lumen Output	2000lm	4000lm
Operating Mode	Maintained	
Classification	C0=D63 C90=D20	
Applicable Standard	AS/NZS2293.3	
Battery	1800mAh	
Beam Angle	100°	
Construction	Powder coated steel body with polycarbonate lamp holders & tamper proof stainless steel clips	
Terminal Block	12mm	
Dimensions (mm)	660x128x87	1270x128x87
Weight	2.1kg	4kg

## Plug-in Microwave Sensor for Batten

TRADELIKE



### FEATURES

- Microwave sensor is design to compatible with GWB1802 series and GWWB1902 series
- Standby light operating at 0-50% brightness (adjustable), full brightness when movement detected
- High performance with range up to 15m and 360 degree
- Sensor operating interval is 2sec - 10mins (adjustable)
- Smart lux detect - day mode and night mode
- Adjustable light starts < 20lux

### SPECIFICATIONS

Antec Order Code	EL-BATT-SENSOR-PLUG IN
Input Voltage	DC5-10v
Dimming Options	No
Dimensions (mm)	74.7x34x37.35
Weight	0.2kg

### DIMENSIONS

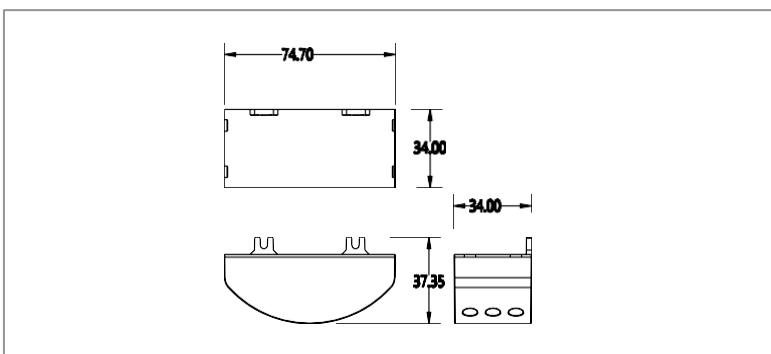

## Emergency LED Downlights - White

TRADELIKE



### FEATURES

- Low power consumption
- 50,000hr LED - energy efficient, long life
- Quick fit bracket for fast ceiling and wall mount
- Easy testing and maintenance

#### Non-maintained

- 3 hour discharge
- 3 year warranty
- 1.2m flex and plug (recessed only - surface mounted hard-wired)
- Designed and manufactured to AS/NZS2293.3

### DIMENSIONS

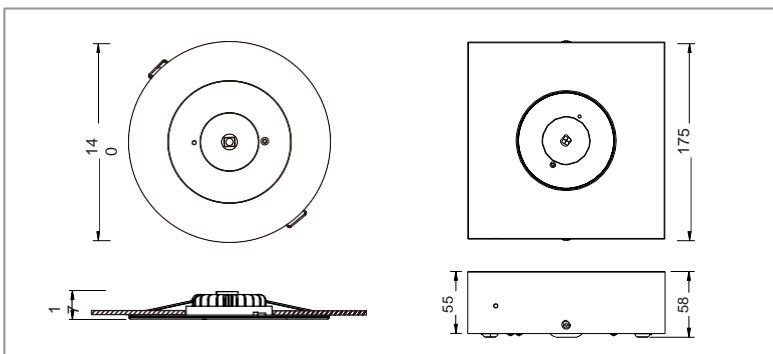

### SPECIFICATIONS

	Recessed	Surface Mount
Antec Order Code	EL-DOWN-REC	EL-DOWN-SM
Input Voltage	240v	
Wattage	3w	
Construction	Polycarbonate body with aluminium heat sink	
Mounting	Recessed and surface mounted	
Operating Mode	Maintained	
Testing System	Manual	
Battery	Lithium 2200mAh 3 hour discharge	
AS2293 Classification	D40	
Applicable Standard	AS/NZS2293.3	
Operating Temp	1°C to 40°C	
Dimensions (mm)	140x17	175x58
Weight	0.45kg	0.93kg

## Emergency LED Downlights - Black

TRADELIKE



### FEATURES

- Low power consumption
- 50,000hr LED - energy efficient
- Quick fit bracket for fast ceiling and wall mount
- Easy testing
- Maintenance Non-maintained
- 3 hour discharge
- 3 year warranty
- 1.2m flex and plug (recessed only) - surface mounted hard-wired
- Designed and manufactured to AS/NZS2293.3

### DIMENSIONS

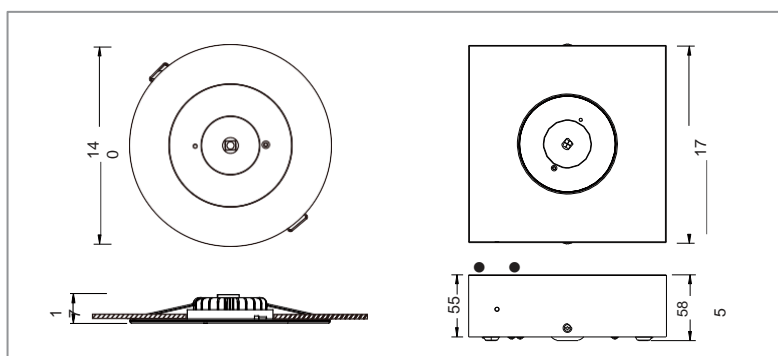

### SPECIFICATIONS

	Recessed	Surface Mount
Antec Order Code	EL-DOWN-REC-BLK	EL-DOWN-SM-BLK
Input Voltage	240v	
Wattage	3w	
Construction	Polycarbonate body with aluminium heat sink	
Mounting	Recessed and surface mounted	
Operating Mode	Maintained	
Testing System	Manual	
Battery	Lithium 2200mAh 3 hour discharge	
AS2293 Classification	D40	
Applicable Standard	AS/NZS2293.3	
Operating Temp	1C to 40C	
Dimensions (mm)	140x17	175x58
Weight	0.45kg	0.93kg

## 20W LED Oyster Emergency Light

TRADELIKE



### FEATURES

#### Maintained

- 3 hour discharge
- 3 year warranty
- Constant current driver
- 1800mAh lithium battery technology
- Built-in LED panel
- Colour temp 5700k
- Large 6mm terminal block for easy installation
- Designed and manufactured to AS2293.3

### DIMENSIONS

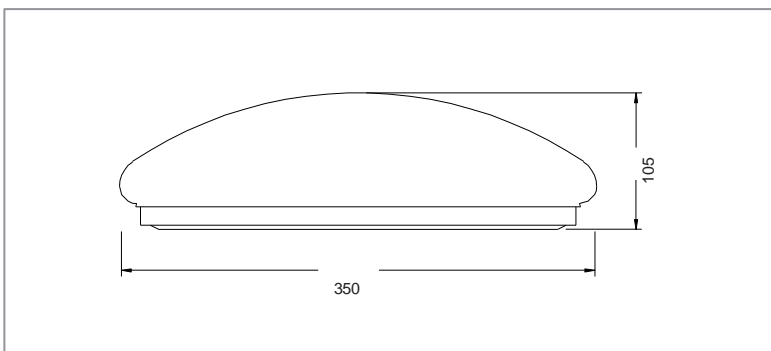

### SPECIFICATIONS

Antec Order Code	EL-OYS-20W
Input Voltage	240v
Wattage	20w
Lumen Output	2000lm
Colour Temp	5700k
Beam Angle	120°
Diffuser	Opal
Operating Mode	Maintained
Testing System	Manual
Battery Type	Lithium 1800mAh 3 hour discharge
AS2293 Classification	C0=D50 C90=D20
Applicable Standard	AS/NZS2293.3
Operating Temp	1°C to 40°C
Dimensions (mm)	350x105
Weight	1.5kg

## 28W LED Oyster Emergency Light

TRADELIKE



Emergency



RA > 80



### FEATURES

#### Maintained

- 3 hour discharge
- 3 year warranty
- Constant current driver
- 1800mAh lithium battery technology
- Built-in LED panel
- Colour temp 5700k
- Large 6mm terminal block for easy installation
- Designed and manufactured to AS/NZS2293.3

### DIMENSIONS

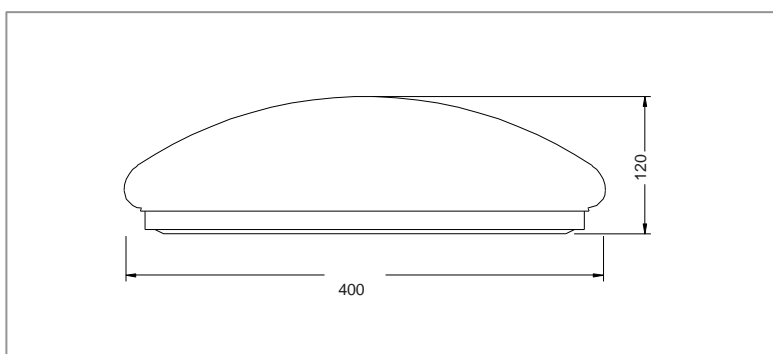

### SPECIFICATIONS

Antec Order Code	EL-OYS-28W
Input Voltage	240v
Wattage	28w
Lumen Output	2500lm
Beam Angle	120°
Colour Temp	5700k
Diffuser	Opal
Operating Mode	Maintained
Testing System	Manual
Battery Type	Lithium 1800mAh 3 hour discharge
AS2293 Classification	C0=D50 C90=D20
Applicable Standard	AS/NZS2293.3
Operating Temp	1C to 40C
Dimensions (mm)	400x120
Weight	1.8kg

## LED Bulkhead Emergency Light

TRADELIKE



### FEATURES

- Surface mount 25w weatherproof
- emergency Polycarbonate diffuser
- Powder coated die-cast
- aluminum body IK10 vandal resistant for general circulation areas
- Ceiling and wall mount
- Non-dimmable
- temp 4000k
- Classification D50

### DIMENSIONS

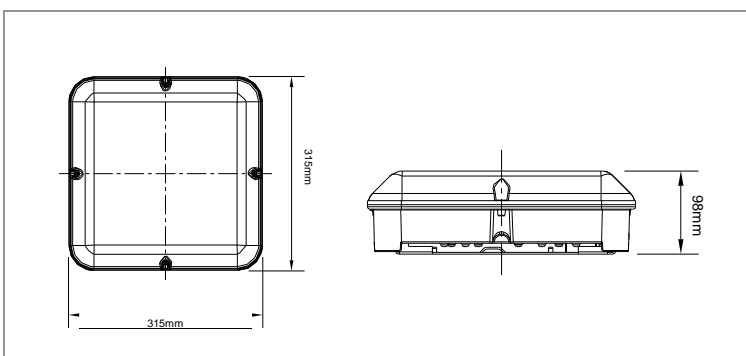

### SPECIFICATIONS

	Emergency	Emergency with Sensor
Antec Order Code	EL-BULKDHEAD-LED	EL-BULKDHEAD-LED-MV
Input Voltage	240 v	
Wattage	25w - 6w (Emergency)	
Lumen Output	3000lm	
IP Rating	IP65	
Beam Angle	120°	
Colour Temp	4000k	
Operating Mode	Maintained	
Battery	Lithium 1800mAh	
AS2293 Classification	C0=D63 C90=D25	
Construction	Die-cast aluminium base with polycarbonate diffuser	
Sensor Function	No	Yes
Terminal Block	6mm	
Dimensions (mm)	315x315x98	
Weight	3.5kg	



## Twin Spot IP65 LED Emergency Light

TRADELIKE



### FEATURES

- Low power consumption
- Wall mount
- Easy testing and maintenance
- Non-maintained
  - 3 hour discharge
  - Polycarbonate body
  - Designed and manufactured to AS/NZS2293.3

### DIMENSIONS

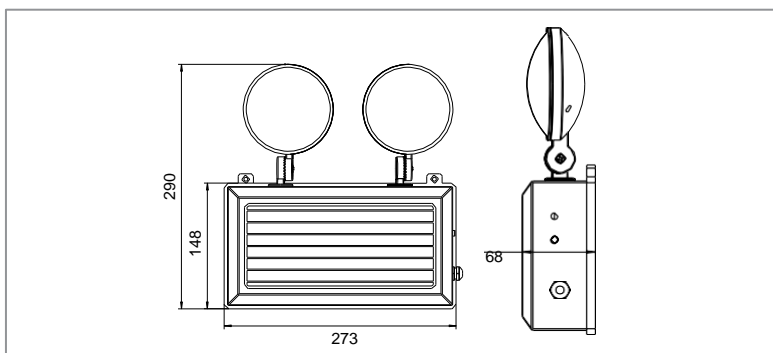

### SPECIFICATIONS

Antec Order Code	EL-FLOOD-TWIN
Input Voltage	240v
Wattage	2 x 3w
Construction	Polycarbonate body
Mounting	Wall mounting
Beam Angle	120°
Operating Mode	Non Maintained
Testing System	Manual
Battery	Lithium 2200mAh 3 hour discharge
AS2293 Classification	C0=D40 C90=D40
Applicable Standard	AS/NZS2293.3
Operating Temp	1°C to 40°C
Battery	3 hour discharge
Dimensions (mm)	290x273x68
Weight	0.92kg

## Exit Sign Conversion Plate

TRADELIKE



### ■ FEATURES

- White powder coated steel conversion plate
- For use with the Antec "Jade" exit sign
- Mounting holes pre-punched
- internal folded lips to strengthen plate
- Available in white and black finishes

### ■ SPECIFICATIONS

Antec Order Code	
- White	EL-PLATE-REC
- Black	EL-PLATE-REC-BLK
Construction	Powder coated steel
Mounting Method	Recessed
Dimensions (mm)	550x150
Weight	0.417kg

### ■ DIMENSIONS

