

## LED Exit Light Jumbo

TRADELIKE



### FEATURES

- 40m viewing distance
- Comes with both single and double sided decals in running man "Pictograph" and the "EXIT" decal
- Large terminal block & cable entry
- Powder coated metal frame with polycarbonate diffuser
- Wall, ceiling single-sided & ceiling double-sided Maintained
- Manual test switch
- 3 year warranty
- 2200mAh lithium battery technology
- Designed and manufactured to AS/NZS2293.3

### DIMENSIONS

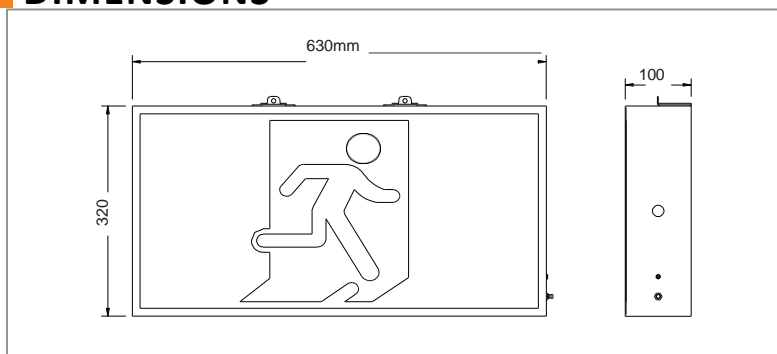

### SPECIFICATIONS

|                     |                                     |
|---------------------|-------------------------------------|
| Antec Order Code    | EL-JUMBO                            |
| Input Voltage       | 240v                                |
| Construction        | Polycarbonate                       |
| Mounting            | Ceiling and wall                    |
| Operating Mode      | Maintained                          |
| Testing System      | Manual                              |
| Battery             | Lithium 2200mAh<br>3 hour discharge |
| Classification      | C0: D12.5<br>C90:D8                 |
| Viewing Distance    | 40m                                 |
| Applicable Standard | AS/NZS2293.3                        |
| Lamps               | LED 50,000hrs                       |
| Operating Temp      | 1°C to 40°C                         |
| Dimensions (mm)     | 630x320x100                         |
| Weight              | 4.22kg                              |